



FRABO

frabo
press
316 M
AX0040

BREVETTATO



Specifiche tecniche

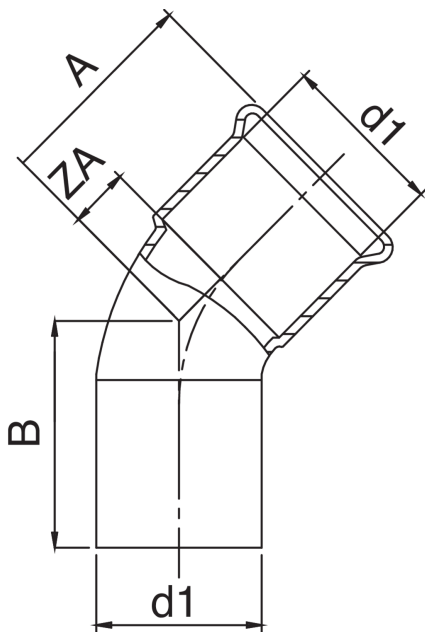

D1	BAG	MASTER BOX	CODICE	A	B	ZA
76,1	1	5	AX0040076076000	98	117	43
88,9	1	3	AX0040089089000	112	131	49
108	1	3	AX0040108108000	138	154	61

Applicazioni



DRINKING
WATER



HEATING



HVAC



COMPRESSED
AIR



FIREFIGHTING



MARINE



STEAM



SOLAR



INDUSTRIAL