

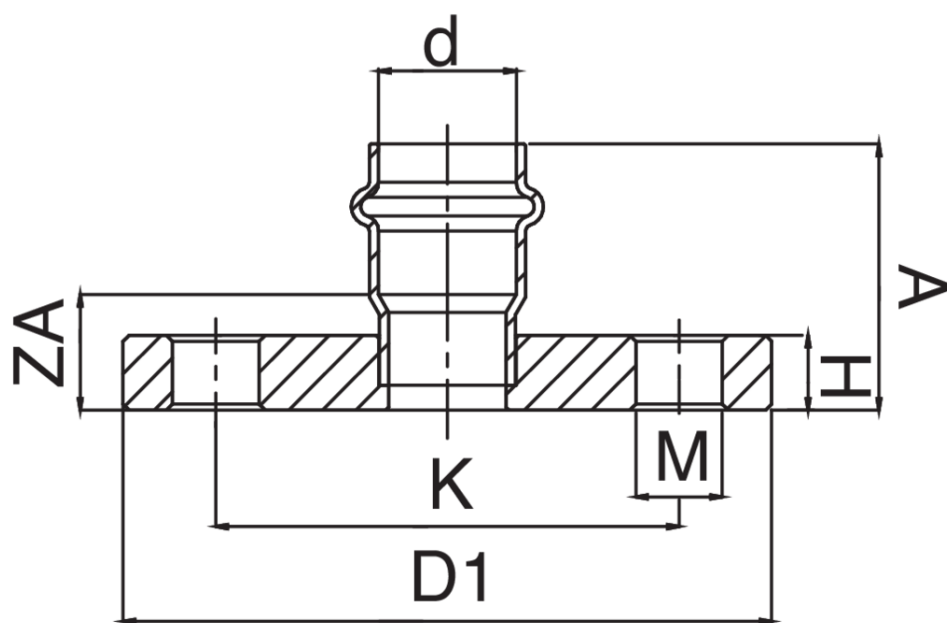

Manicotto femmina flangiato PN10/16.

Specifiche tecniche



D	BAG	MASTER BOX	CODICE	N° FORI	A	D1	H	K	M	ZA
22	1	10	ZX0273022000000	4	46,5	105	12	75	14	22,5
28	1	5	ZX0273028000000	4	49	115	14	85	14	24
35	1	5	ZX0273035000000	4	49	140	15	100	18	23
42	1	3	ZX0273042000000	4	61,5	150	16	110	18	20,5
54	1	2	ZX0273054000000	4	65,5	165	18	125	18	20,5

Disponibile versione big-size, art. AX0273.

Applicazioni



DRINKING
WATER



HEATING



HVAC



COMPRESSED
AIR



FIREFIGHTING



MARINE



STEAM



SOLAR



INDUSTRIAL