

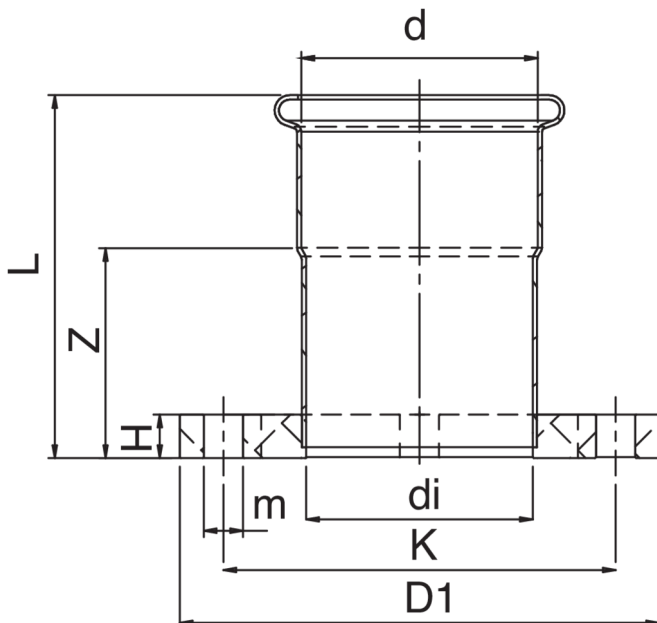

Manicotto flangiato F PN16.

## Specifiche tecniche



D	BAG	MASTER BOX	CODICE	DI	D1	H	K	L	M	Z	N° HOLE
35	2	20	CM0273035000000	140	32	53	14	18	100	26	4
42	2	10	CM0273042000000	150	39	56,5	13	18	110	26,5	4
54	2	10	CM0273054000000	165	51	65	15	18	125	30	4

# Applicazioni



HEATING



HVAC



COMPRESSED  
AIR