

F/female thread adapter.

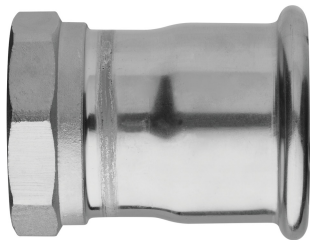

Specifiche tecniche

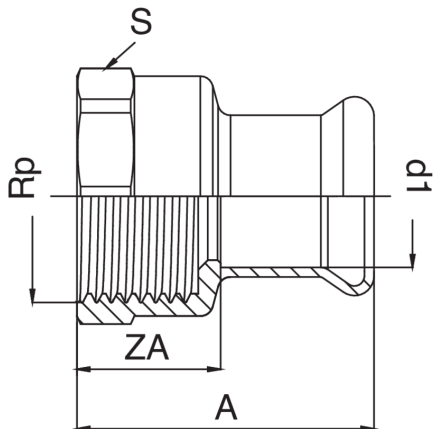

D X RP	BAG	MASTER BOX	CODICE	I	L	S	ZA
76,1 x 2"1/2	1	8	AXF270C12076000	55	114	86	59
88,9 x 3"	1	5	AXF270D03089000	60	123,5	98	63
108 x 4"	1	3	AXF270E04108000	70	153	122	83

Applicazioni



DRINKING WATER



HEATING



HVAC



COMPRESSED AIR



FIREFIGHTING



MARINE



STEAM



SOLAR



INDUSTRIAL