

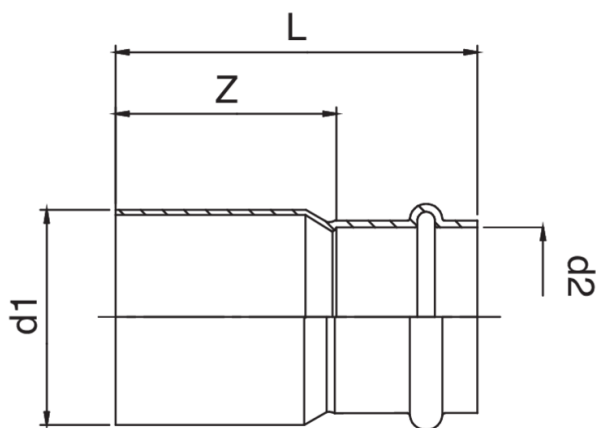

Manicotto di riduzione maschio-femmina.



Specifiche tecniche



D1 X D2	BAG	MASTER BOX	CODICE	L	Z
76.1 x 42*	1	10	AX0243076042000	149,5	108,5
76.1 x 54*	1	10	AX0243076054000	152,5	107,5
88.9 x 54*	1	4	AX0243089054000	194	149
108 x 54*	1	6	AX0243108054000	260	215

*Profilo V.

Applicazioni



DRINKING WATER



HEATING



HVAC



COMPRESSED AIR



FIREFIGHTING



MARINE



STEAM



SOLAR



INDUSTRIAL