

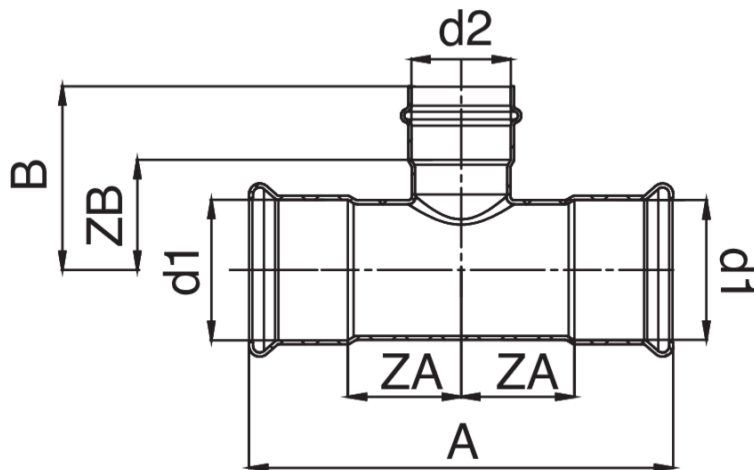

F/F/F reducing tee.



## Specifiche tecniche



D1 X D2 X D1	BAG	MASTER BOX	CODICE	A	B	ZA	ZB
76.1 x 22* x 76.1	1	5	AX0131076022076	152	80,5	25	56,5
76.1 x 28* x 76.1	1	7	AX0131076028076	152	83	25	58
76.1 x 35* x 76.1	1	5	AX0131076035076	242	84	66	58
76.1 x 42* x 76.1	1	5	AX0131076042076	242	91,5	66	55,5
76.1 x 54* x 76.1	1	5	AX0131076054076	242	101	66	61
88.9 x 22* x 88.9	1	3	AX0131089022089	175	87	27	63
88.9 x 28* x 88.9	1	2	AX0131089028089	175	89,5	27	64,5
88.9 x 35* x 88.9	1	2	AX0131089035089	272	90,5	76	64,5
88.9 x 42* x 88.9	1	4	AX0131089042089	272	98	76	62
88.9 x 54* x 88.9	1	4	AX0131089054089	272	107,5	76	67,5
108 x 22* x 108	1	2	AX0131108022108	204	96,5	33	73,5
108 x 28* x 108	1	2	AX0131108028108	204	99	33	74
108 x 35* x 108	1	2	AX0131108035108	324	100	92	74
108 x 42* x 108	1	2	AX0131108042108	324	107,5	92	71,5
108 x 54* x 108	1	2	AX0131108054108	324	117	92	77

\*Profilo V.

## Applicazioni



DRINKING  
WATER



HEATING



HVAC



COMPRESSED  
AIR



FIREFIGHTING



MARINE



STEAM



SOLAR



INDUSTRIAL