

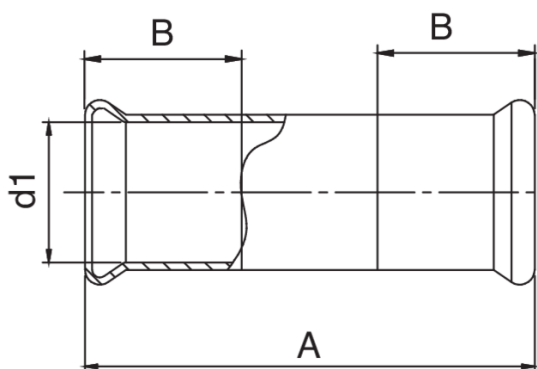

Manicotto femmina passante.



Specifiche tecniche



D1	BAG	MASTER BOX	CODICE	A	B
76,1*	1	5	AX0271076076000	242	55
88,9*	1	1	AX0271089089000	272	60
108*	1	3	AX0271108108000	324	70

* Profilo M.

Applicazioni



DRINKING WATER



HEATING



HVAC



COMPRESSED AIR



FIREFIGHTING



MARINE



STEAM



SOLAR



INDUSTRIAL