

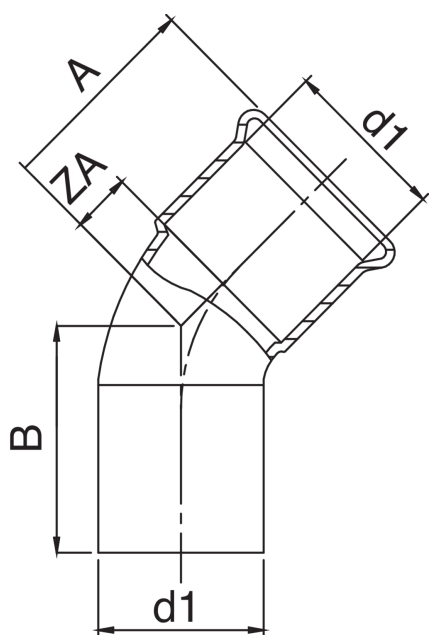

Curva 45° maschio-femmina.



Specifiche tecniche



D1	BAG	MASTER BOX	CODICE	A	B	ZA
76,1*	1	5	AX0040076076000	98	117	43
88,9*	1	3	AX0040089089000	112	131	49
108*	1	3	AX0040108108000	138	154	61

* Profilo M.

Applicazioni



DRINKING
WATER



HEATING



HVAC



COMPRESSED
AIR



FIREFIGHTING



MARINE



STEAM



SOLAR



INDUSTRIAL