

Manicotto di riduzione maschio-femmina.

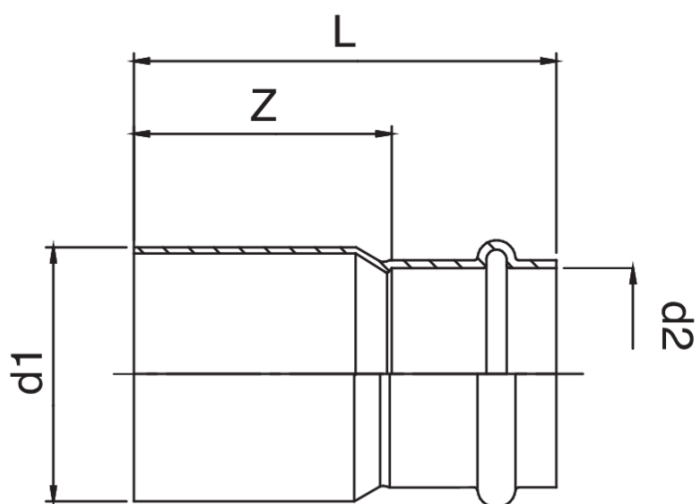

Specifiche tecniche



D1 X D2	BAG	MASTER BOX	CODICE	L	Z
76.1 x 54*	1	5	RR9243076054000	146	106
88.9 x 54*	1	5	RR9243089054000	190	150
108 x 54*	1	5	RR9243108054000	253	213

* Guarnizione in EPDM uso acqua.

Applicazioni



DRINKING WATER



HEATING



HVAC



GAS



COMPRESSED AIR



FIREFIGHTING