

Manchon coulissant F/F.

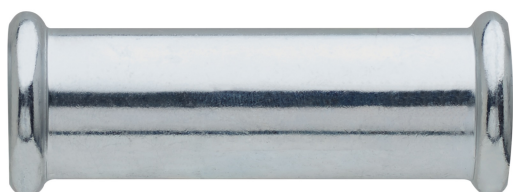

Spécifications techniques

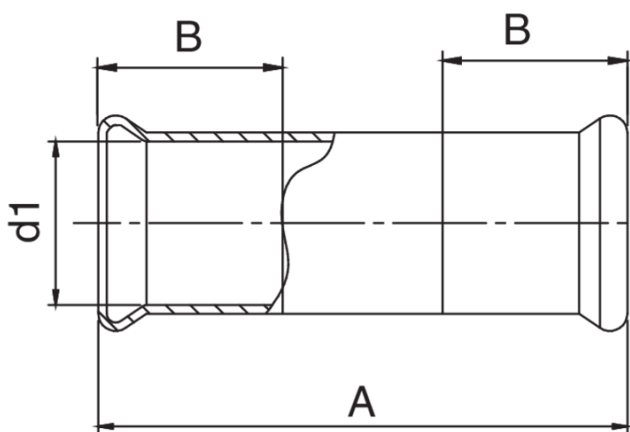

| D1 | BAG | MASTER BOX | CODE | A |
|------|-----|------------|-----------------|-----|
| 66,7 | 1 | 10 | AC0271067067000 | 232 |
| 76,1 | 1 | 8 | AC0271076076000 | 242 |
| 88,9 | 1 | 6 | AC0271089089000 | 272 |
| 108 | 1 | 3 | AC0271108108000 | 324 |

Applications



HEATING



HVAC



COMPRESSED
AIR