



**FRABO**

**TURBO**  
CuNi  
**5N3800**



Courbe 60° F/F.

## Spécifications techniques

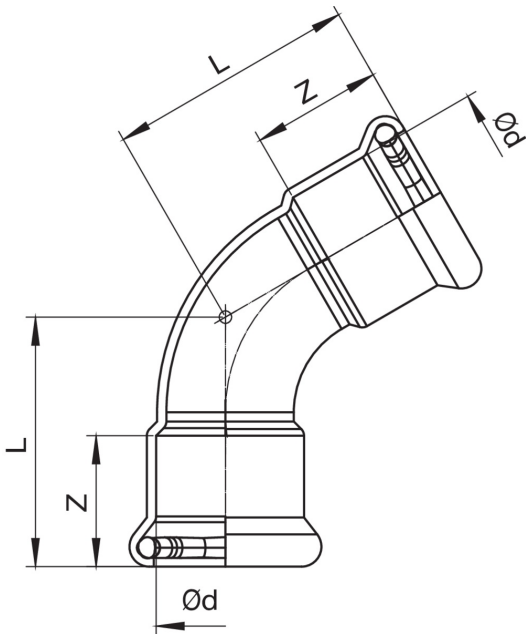

D	BAG	MASTER BOX	CODE	L	Z
15	10	250	5N380015	34	19
18	10	250	5N380018	36	19,5
22	5	120	5N380022	42,5	21
28	5	60	5N380028	46,5	22
35	5	50	5N380035	69	27
42	2	24	5N380042	88,5	30
54	2	16	5N380054	112,5	35
76,1	1	5	5N380076	120	54
88,9	1	3	5N380088	137	61
108	1	2	5N380108	181,5	76

## Applications



MARINE