

RG5041

Courbe 45° F/F.

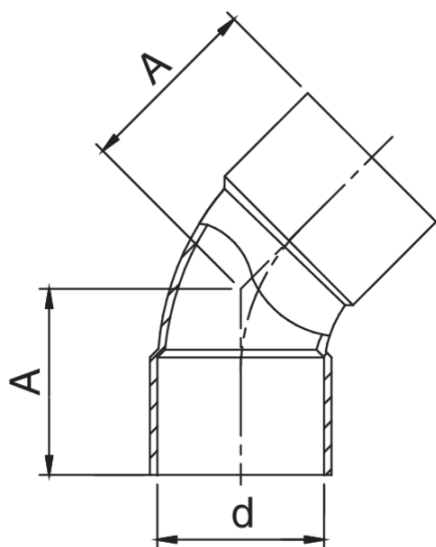

Spécifications techniques



| D | BAG | MASTER BOX | CODE | A |
|-----|-----|------------|-----------------|------|
| 22 | 10 | 350 | RG5041022022000 | 27 |
| 28 | 10 | 200 | RG5041028028000 | 33,5 |
| 35 | 5 | 100 | RG5041035035000 | 40 |
| 42 | 5 | 60 | RG5041042042000 | 46 |
| 54 | 1 | 10 | RG5041054054000 | 55,5 |
| 133 | 1 | 2 | RG5041133133000 | 110 |

Applications



GAS



COMPRESSED AIR



SOLAR



INDUSTRIAL



REFRIGERATION



DRINKING WATER



HVAC