

RG5001

Courbe 90° M/F.

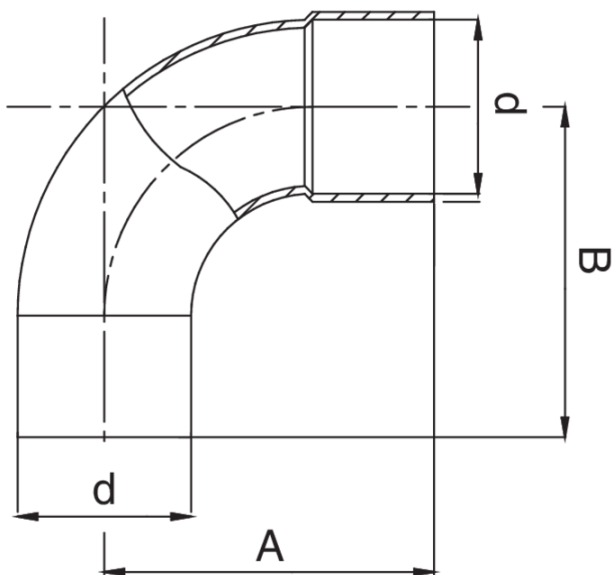

Spécifications techniques



D	BAG	MASTER BOX	CODE	A	B
22	10	100	RG5001022022000	44	46
28	10	50	RG5001028028000	55	57
35	5	80	RG5001035035000	68	70
42	5	50	RG5001042042000	80	81
54	1	10	RG5001054054000	100	102
64	1	5	RG5001064064000	112	114
133	1	1	RG5001133133000	209	212

# Applications



GAS



COMPRESSED AIR



SOLAR



INDUSTRIAL



REFRIGERATION



DRINKING WATER



HVAC