

Té F/F/F.

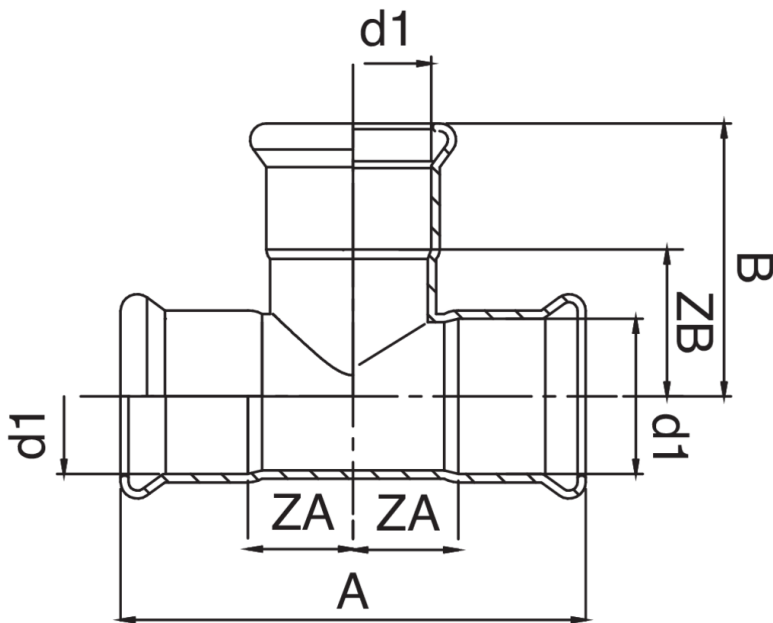

Spécifications techniques



D1	BAG	MASTER BOX	CODE	A	B	ZA	ZB
15	5	40	MX0130015015015	68	34	14,5	14,5
18	5	50	MX0130018018018	70	35	15,5	15,5
22	5	30	MX0130022022022	79	39,5	17	17
28	5	20	MX0130028028028	92	46	23,5	23,5
35	1	15	MX0130035035035	106	53	27,5	27,5
42	1	10	MX0130042042042	124	62	32,5	32,5
54	1	5	MX0130054054054	146	73	38,5	38,5

Applications



DRINKING
WATER



HEATING



HVAC



COMPRESSED
AIR



FIREFIGHTING



MARINE



STEAM



SOLAR



INDUSTRIAL