

Manchon coulissant F/F en cuivre.

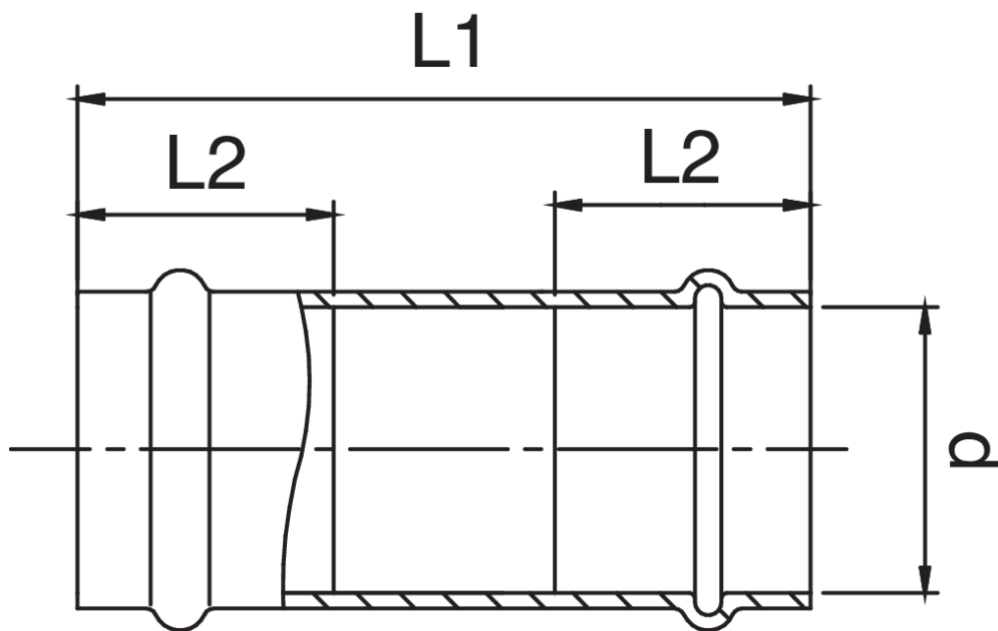

## Spécifications techniques



D	BAG	MASTER BOX	CODE	L1	L2
12	10	150	PG9271012012000	58	18
15	10	150	PG9271015015000	82	22
18	10	100	PG9271018018000	92	23
22	5	60	PG9271022022000	97	24
28	5	40	PG9271028028000	107	25
35	5	30	PG9271035035000	114	26
42	5	15	PG9271042042000	142	41
54	1	10	PG9271054054000	163	45

## Applications



GAS



INDUSTRIAL



COMPRESSED  
AIR