

Tapón Hembra.

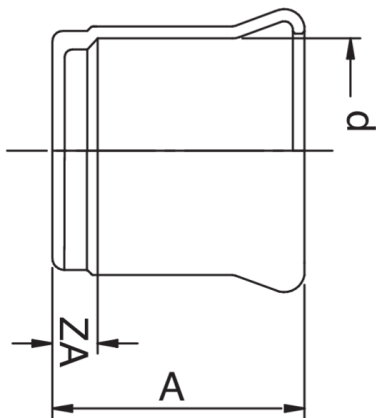

Especificaciones técnicas



D	BAG	MASTER BOX	CÓDIGO	A	ZA
76,1	1	10	AX0302076000000	81	26
88,9	1	5	AX0302089000000	89	29
108	1	6	AX0302108000000	109	39

Aplicaciones



DRINKING WATER



HEATING



HVAC



COMPRESSED AIR



FIREFIGHTING



MARINE



STEAM



SOLAR



INDUSTRIAL