

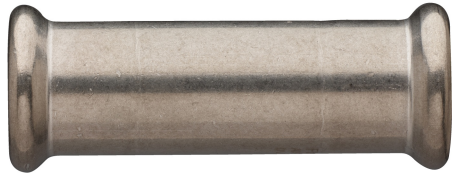

FRABO

frabo
press
316 M
AX0271

PATENTED



Manguito de paso H/H.



Especificaciones técnicas

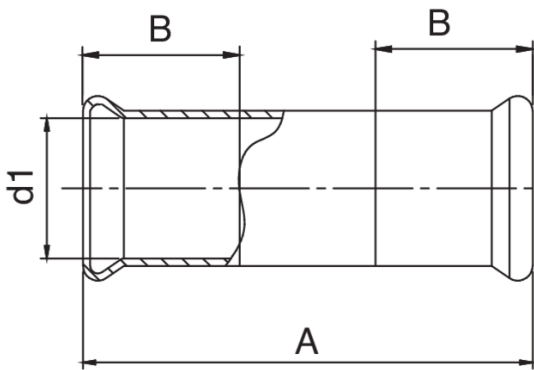

D1	BAG	MASTER BOX	CÓDIGO	A
76,1	1	5	AX0271076076000	242
88,9	1	1	AX0271089089000	272
108	1	3	AX0271108108000	324

Aplicaciones



DRINKING WATER



HEATING



HVAC



COMPRESSED AIR



FIREFIGHTING



MARINE



STEAM



SOLAR



INDUSTRIAL