

Manguito con remante H/H.

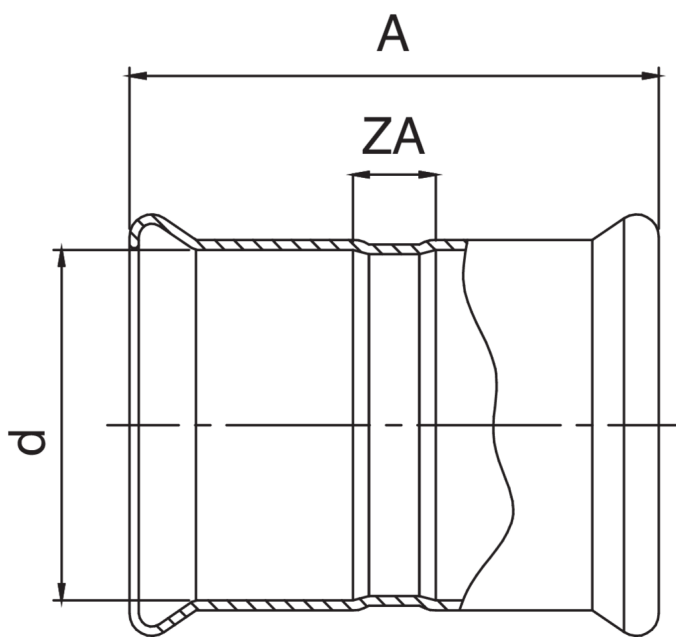

Especificaciones técnicas



D	BAG	MASTER BOX	CÓDIGO	A	ZA
76,1	1	5	AX0270076076000	152	50
88,9	1	5	AX0270089089000	175	54
108	1	5	AX0270108108000	204	66

Aplicaciones



DRINKING WATER



HEATING



HVAC



COMPRESSED AIR



FIREFIGHTING



MARINE



STEAM



SOLAR



INDUSTRIAL