

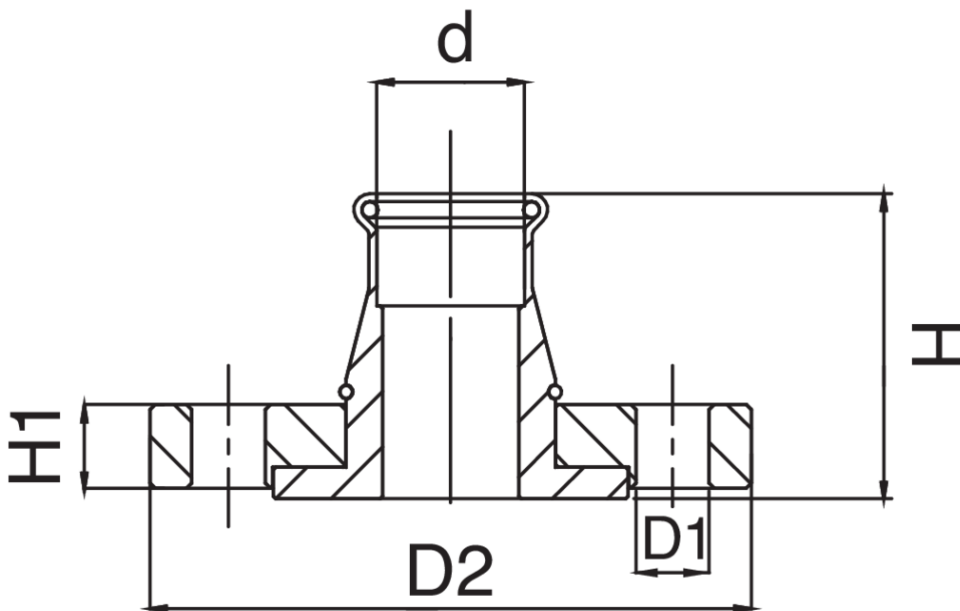

Manguito bridado de bronce.



Especificaciones técnicas



D	BAG	MASTER BOX	CÓDIGO	D1	D2	H	H1
66,7*	1	2	RR9273067000000	18	165	95	18
76,1*	1	2	RR9273076000000	18	185	105	18
76,1*	1	2	RR9273076080000	18	200	105	20
88,9*	1	2	RR9273089000000	18	200	110	20
108*	1	2	RR9273108000000	18	220	128	20

* Copper. No Securfrabo system.

Aplicaciones



DRINKING
WATER



HEATING



HVAC



COMPRESSED
AIR



FIREFIGHTING