

Manguito mixto H/rosca hembra de bronce.

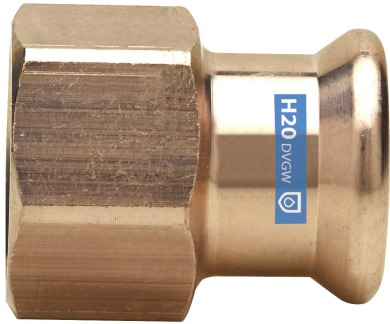

## Especificaciones técnicas

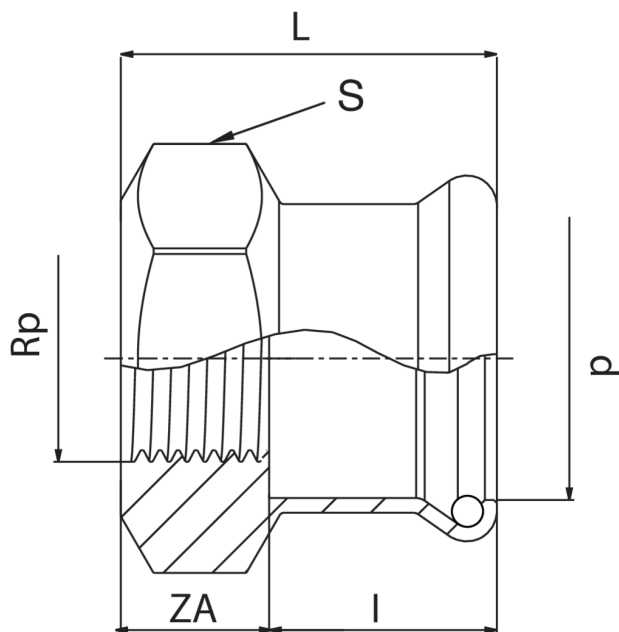

D X RP	BAG	MASTER BOX	CÓDIGO	I	L	S	ZA
76,1 x 2"1/2	1	8	RB8270C12076000	55	93	86	38
88,9 x 3"	1	5	RB8270D03089000	55	95	98	40

# Aplicaciones



DRINKING WATER



HEATING



HVAC



COMPRESSED AIR



FIREFIGHTING