

Manguito con remante H/H de cobre.

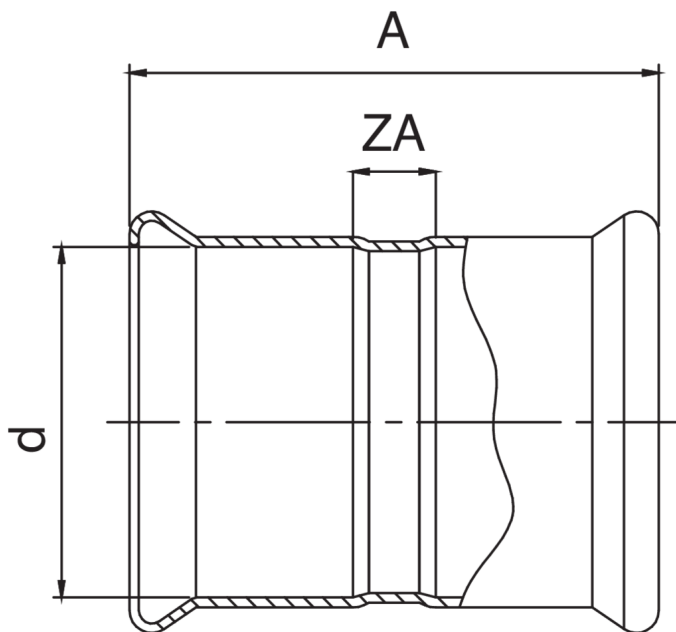

Especificaciones técnicas



D	BAG	MASTER BOX	CÓDIGO	A	ZA
66,7	1	20	RR9270067067000	130	40
76,1	1	12	RR9270076076000	154	54
88,9	1	10	RR9270089089000	173	53
108	1	1	RR9270108108000	204	64

Aplicaciones



DRINKING WATER



HEATING



HVAC



COMPRESSED AIR



FIREFIGHTING