

**RG5092**

Codo 90° M/H.

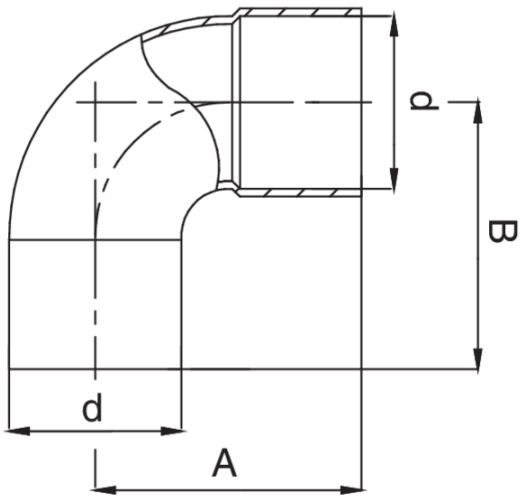

Especificaciones técnicas



D	BAG	MASTER BOX	CÓDIGO	A	B
22	10	300	RG5092022022000	33	35
28	10	150	RG5092028028000	45	47
35	5	90	RG5092035035000	53	55
42	5	40	RG5092042042000	61	63
54	1	10	RG5092054054000	74	76

# Aplicaciones



GAS



COMPRESSED AIR



SOLAR



INDUSTRIAL



REFRIGERATION



DRINKING WATER



HVAC