

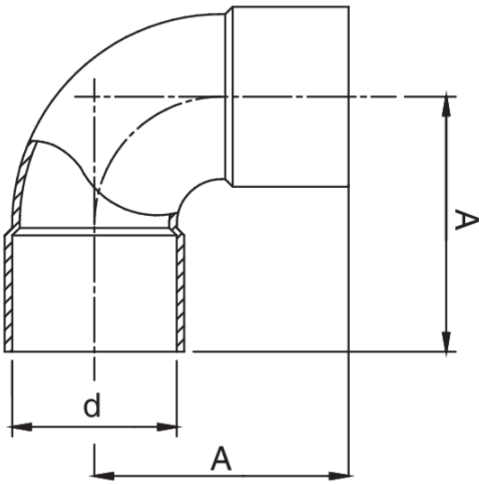

## Especificaciones técnicas



D	BAG	MASTER BOX	CÓDIGO	A
35	5	90	RG5090035035000	54
42	5	40	RG5090042042000	61

# Aplicaciones



GAS



COMPRESSED AIR



SOLAR



INDUSTRIAL



REFRIGERATION



DRINKING WATER



HVAC