

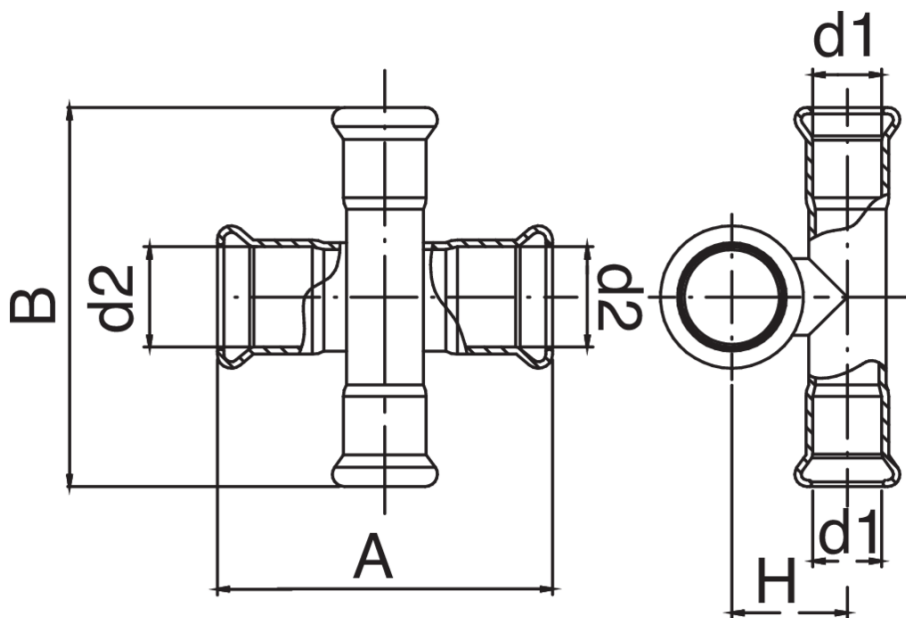

Cruz desplazamiento H/H/H/H.



Especificaciones técnicas



D1 X D2	BAG	MASTER BOX	CÓDIGO	A	B	H
15 x 15	5	40	CM0150015015000	75	75	26
18 x 15	5	40	CM0150018015000	80	75	28
22 x 15	5	30	CM0150022015000	72	75	30
22 x 18	5	30	CM0150022018000	82	80	31
28 x 15	5	20	CM0150028015000	92	75	33
28 x 18	5	20	CM0150028018000	92	80	34
28 x 22	5	30	CM0150028022000	92	82	36
54 x 22	1	10	CM0150054022000	142	82	49

Aplicaciones



HEATING



HVAC



COMPRESSED
AIR