

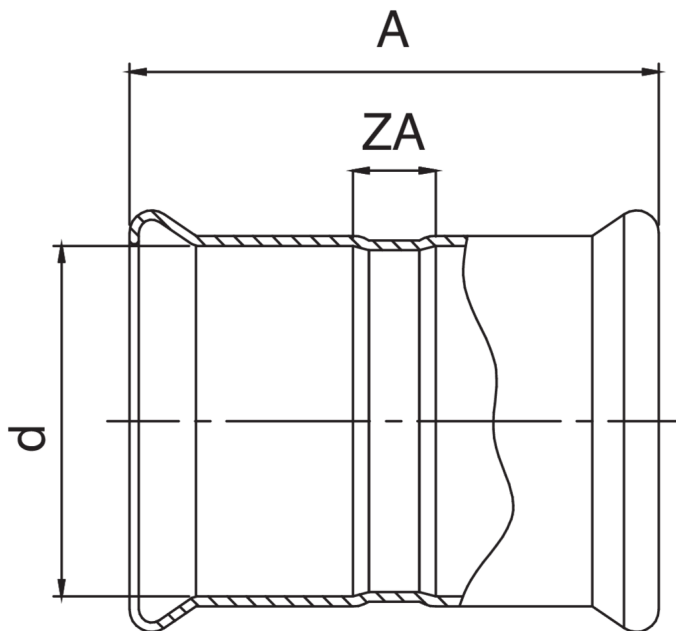

Manguito con remante H/H.



Especificaciones técnicas



D	BAG	MASTER BOX	CÓDIGO	A	ZA
15	10	200	CM0270015015000	50	12
18	10	150	CM0270018018000	48	10
22	10	100	CM0270022022000	57	15
28	10	50	CM0270028028000	57	13
35	5	40	CM0270035035000	68	18
42	5	25	CM0270042042000	74	16
54	1	15	CM0270054054000	86	18

Aplicaciones



HEATING



HVAC



COMPRESSED
AIR