

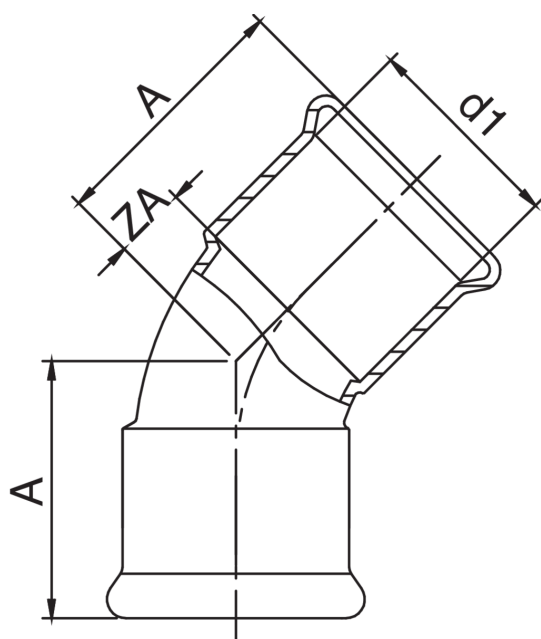

Curva 45° H/H.

Especificaciones técnicas



D1	BAG	MASTER BOX	CÓDIGO	A	ZA
15	10	100	GM0041015015000	29	9,5
18	5	30	GM0041018018000	31	11,5
22	5	50	GM0041022022000	34	11,5
28	5	40	GM0041028028000	38	15,5
35	5	40	GM0041035035000	43	17,5
42	1	20	GM0041042042000	53	23,5
54	1	5	GM0041054054000	69	34,5

Aplicaciones



GAS



COMPRESSED
AIR



INDUSTRIAL