

Manguito con remante H/H.

## Especificaciones técnicas

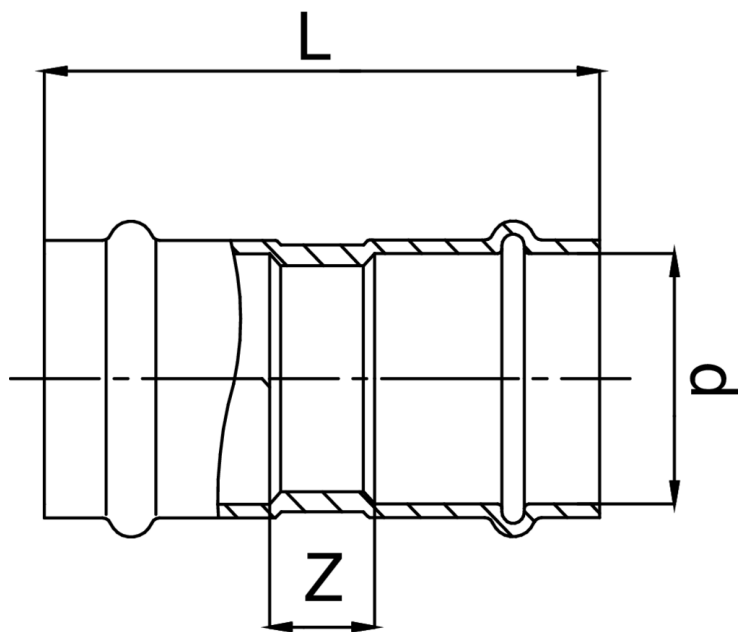

D	BAG	MASTER BOX	CÓDIGO	L	Z
15	10	150	GX0270015015000	57	13
18	10	100	GX0270018018000	71	23
22	5	30	GX0270022022000	71	23
28	5	40	GX0270028028000	80	30
35	5	35	GX0270035035000	84	23
42	1	25	GX0270042042000	97	25
54	1	5	GX0270054054000	107	27

# Aplicaciones



GAS



COMPRESSED  
AIR



INDUSTRIAL