

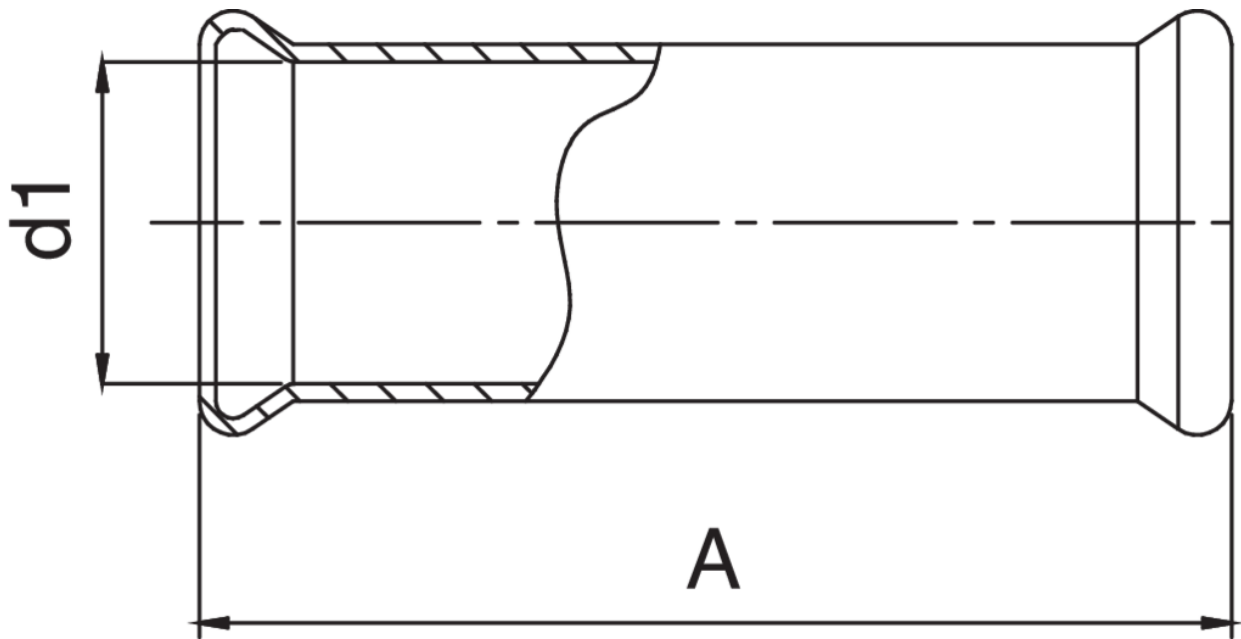

Manguito de paso H/H.



Especificaciones técnicas



D1	BAG	MASTER BOX	CÓDIGO	A
15	10	50	MX0271015015000	80
18	10	40	MX0271018018000	80
22	5	30	MX0271022022000	85
28	5	30	MX0271028028000	95
35	5	30	MX0271035035000	105
42	1	10	MX0271042042000	120
54	1	15	MX0271054054000	135

Aplicaciones



DRINKING WATER



HEATING



HVAC



COMPRESSED AIR



FIREFIGHTING



MARINE



STEAM



SOLAR



INDUSTRIAL