

Manguito con remante H/H.

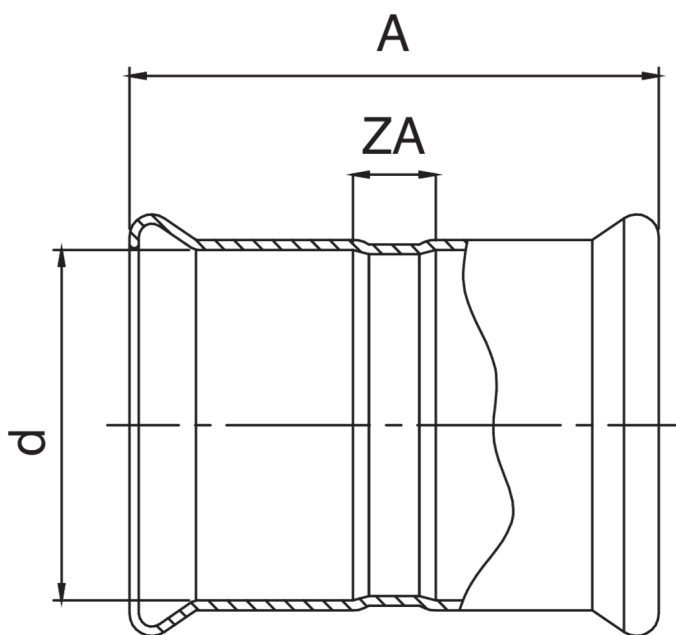

Especificaciones técnicas



D	BAG	MASTER BOX	CÓDIGO	A	ZA
15	10	150	MX0270015015000	48	9
18	10	100	MX0270018018000	48	9
22	5	30	MX0270022022000	50	5
28	5	40	MX0270028028000	54	9
35	5	35	MX0270035035000	62	11
42	1	25	MX0270042042000	73	14
54	1	15	MX0270054054000	85	16

Aplicaciones



DRINKING
WATER



HEATING



HVAC



COMPRESSED
AIR



FIREFIGHTING



MARINE



STEAM



SOLAR



INDUSTRIAL