

Unión sede plana H/H.

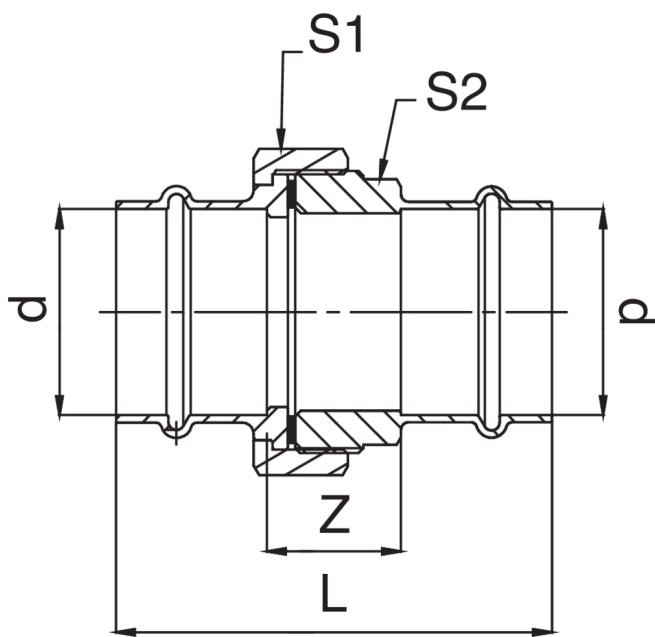

Especificaciones técnicas



D	BAG	MASTER BOX	CÓDIGO	L	S1	S2	Z
15	5	100	ZX0340015015000	90	24	25	46
18	5	100	ZX0340018018000	100	30	30	54
22	5	40	ZX0340022022000	103	37	34	55
28	5	30	ZX0340028028000	96	46	45	46
35	1	20	ZX0340035035000	125	52	50	73
42	1	10	ZX0340042042000	132	64	60	60
54	1	8	ZX0340054054000	148	85	75	68

Aplicaciones



DRINKING WATER



HEATING



HVAC



COMPRESSED AIR



FIREFIGHTING



MARINE



STEAM



SOLAR



INDUSTRIAL