

Manguito con remante H/H de cobre.

## Especificaciones técnicas

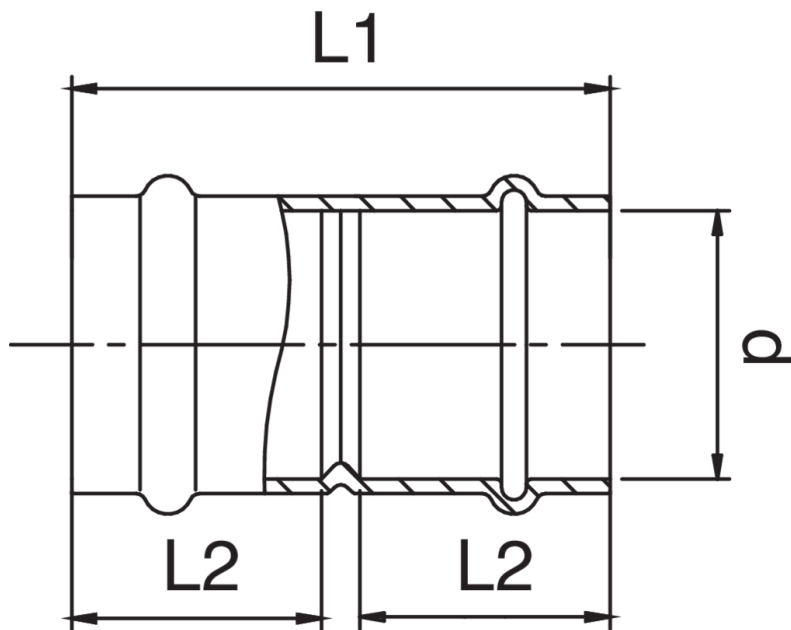

D	BAG	MASTER BOX	CÓDIGO	L1	L2
15	10	200	HT9270015015000	49	22
18	10	150	HT9270018018000	52	23
22	10	100	HT9270022022000	53	24
28	10	60	HT9270028028000	57	25
35	5	40	HT9270035035000	62	26

## Aplicaciones



SOLAR



STEAM



COMPRESSED  
AIR



INDUSTRIAL

