

Manguito con remante H/H de cobre.

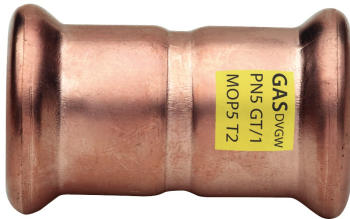

## Especificaciones técnicas

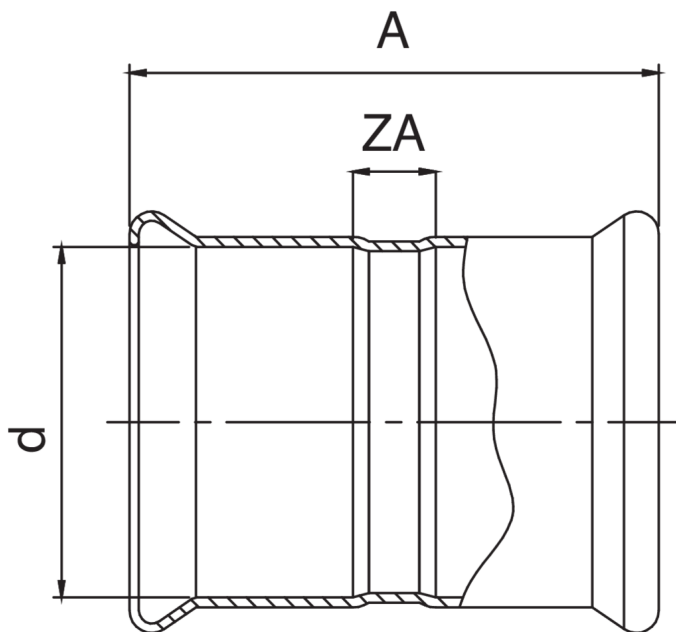

D	BAG	MASTER BOX	CÓDIGO	A	ZA
12	10	300	QM9270012012000	40	4
15	10	200	QM9270015015000	50	10
18	10	150	QM9270018018000	45	5
22	10	100	QM9270022022000	48	2
28	10	60	QM9270028028000	50	4
35	5	40	QM9270035035000	56	4
42	5	25	QM9270042042000	75	15
54	1	15	QM9270054054000	86	16

## Aplicaciones



COMPRESSED  
AIR



GAS



INDUSTRIAL