

Manguito con remante H/H de cobre.

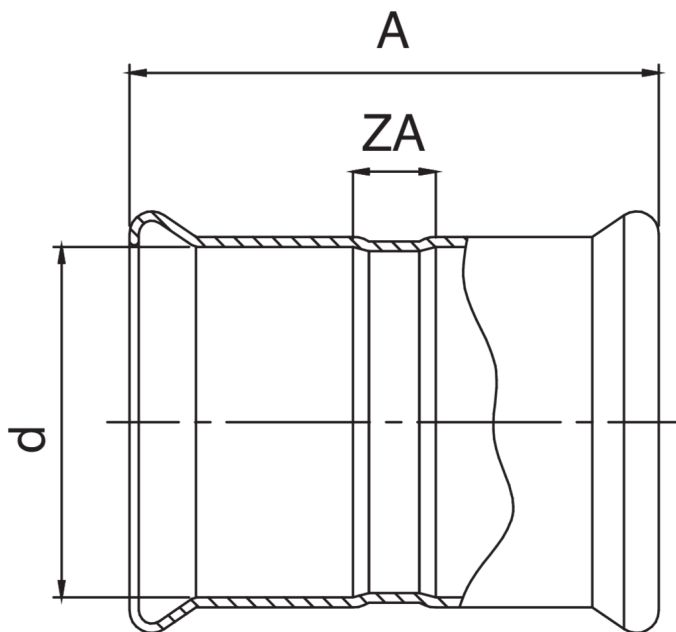

Especificaciones técnicas



| D | BAG | MASTER BOX | CÓDIGO | A | ZA |
|----|-----|------------|-----------------|----|----|
| 12 | 10 | 300 | ZM9270012012000 | 40 | 4 |
| 15 | 10 | 200 | ZM9270015015000 | 50 | 10 |
| 18 | 10 | 150 | ZM9270018018000 | 45 | 5 |
| 22 | 10 | 100 | ZM9270022022000 | 48 | 2 |
| 28 | 10 | 60 | ZM9270028028000 | 50 | 4 |
| 35 | 5 | 40 | ZM9270035035000 | 56 | 4 |
| 42 | 5 | 25 | ZM9270042042000 | 75 | 15 |
| 54 | 1 | 15 | ZM9270054054000 | 86 | 16 |

Aplicaciones



DRINKING WATER



HEATING



HVAC



COMPRESSED AIR



FIREFIGHTING