

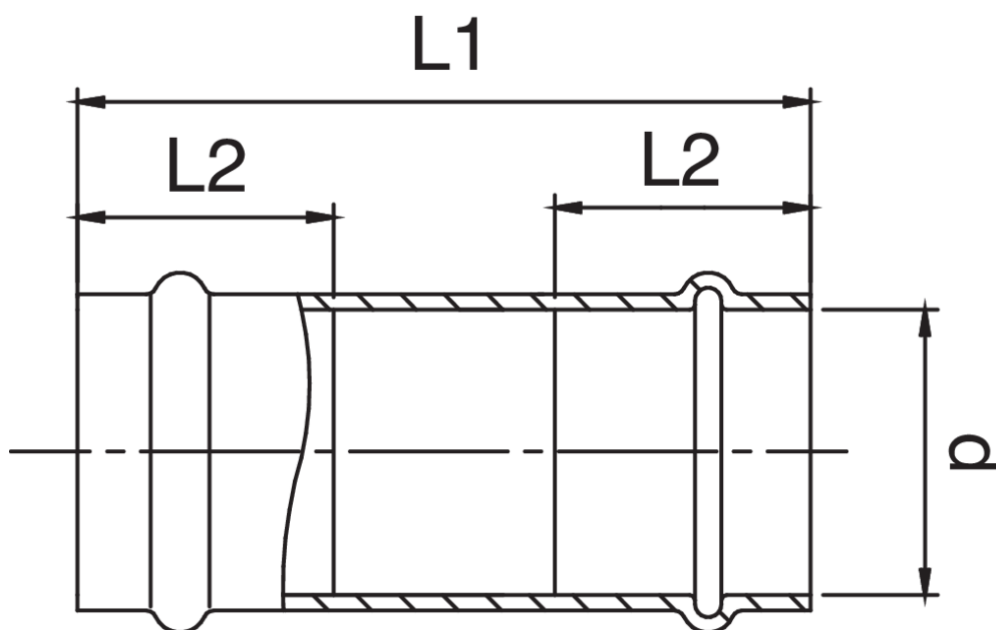

Manguito de paso H/H de cobre.



Especificaciones técnicas



D	BAG	MASTER BOX	CÓDIGO	L1	L2
12	10	150	RS9271012012000	58	18
15	10	100	RS9271015015000	82	22
18	10	100	RS9271018018000	92	23
22	10	60	RS9271022022000	97	24
28	5	40	RS9271028028000	107	25
35	5	30	RS9271035035000	114	26
42	1	15	RS9271042042000	142	41
54	1	10	RS9271054054000	144	45

Aplicaciones



DRINKING WATER



HEATING



HVAC



GAS



COMPRESSED AIR



FIREFIGHTING