

RR5130

T reducido central H/H/H.

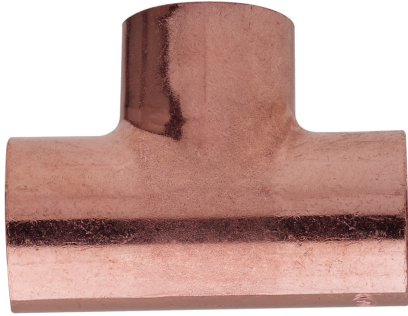

Especificaciones técnicas

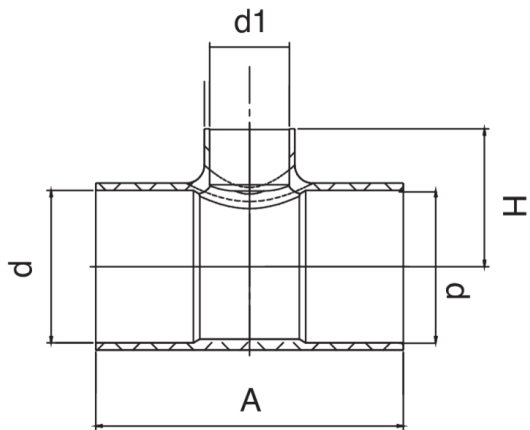

D X D1 X D	BAG	MASTER BOX	CÓDIGO	A	H
52 x 32 x 52	5	10	RR5130052032052	100	52
52 x 42 x 52	1	10	RR5130052042052	110	55
54 x 15 x 54	1	10	RR5130054015054	82	42
54 x 18 x 54	5	20	RR5130054018054	86	42
54 x 22 x 54	5	20	RR5130054022054	90	46
54 x 28 x 54	5	25	RR5130054028054	94	47,5
54 x 35 x 54	1	10	RR5130054035054	101	52,5
54 x 42 x 54	1	10	RR5130054042054	110	57
64 x 42 x 64	1	10	RR5130064042064	120	68
64 x 54 x 64	1	18	RR5130064054064	131	74
76 x 35 x 76	1	15	RR5130076035076	127	68
76 x 42 x 76	1	5	RR5130076042076	128	73
76 x 54 x 76	1	12	RR5130076054076	135	77
89 x 76 x 89	1	5	RR5130089076089	171	87,5
108 x 76 x 108	1	5	RR5130108076108	186	98,5
108 x 89 x 108	1	3	RR5130108089108	200	105

Aplicaciones



DRINKING
WATER



HEATING



HVAC



GAS



COMPRESSED
AIR



SOLAR



INDUSTRIAL