

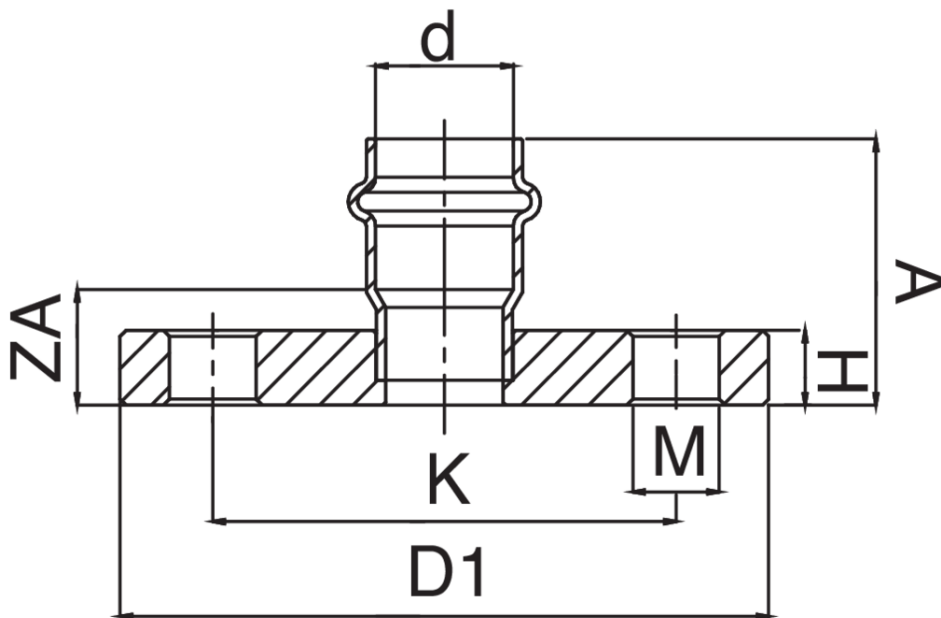

Manguito bridado H PN10/16.



Especificaciones técnicas



D	BAG	MASTER BOX	CÓDIGO	N°HOLES	A	D1	H	K	M	ZA
22	1	10	ZX0273022000000	4	46,5	105	12	75	14	22,5
28	1	5	ZX0273028000000	4	49	115	14	85	14	24
35	1	5	ZX0273035000000	4	49	140	15	100	18	23
42	1	3	ZX0273042000000	4	61,5	150	16	110	18	20,5
54	1	2	ZX0273054000000	4	65,5	165	18	125	18	20,5

The big-size, item AX0273, is available.

Aplicaciones



DRINKING
WATER



HEATING



HVAC



COMPRESSED
AIR



FIREFIGHTING



MARINE



STEAM



SOLAR



INDUSTRIAL