

RG5130

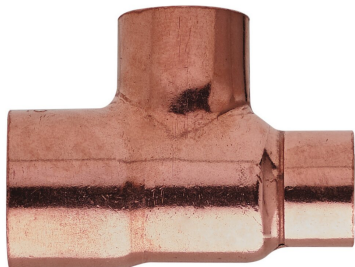

T reducido lateral H/H/H.

Especificaciones técnicas

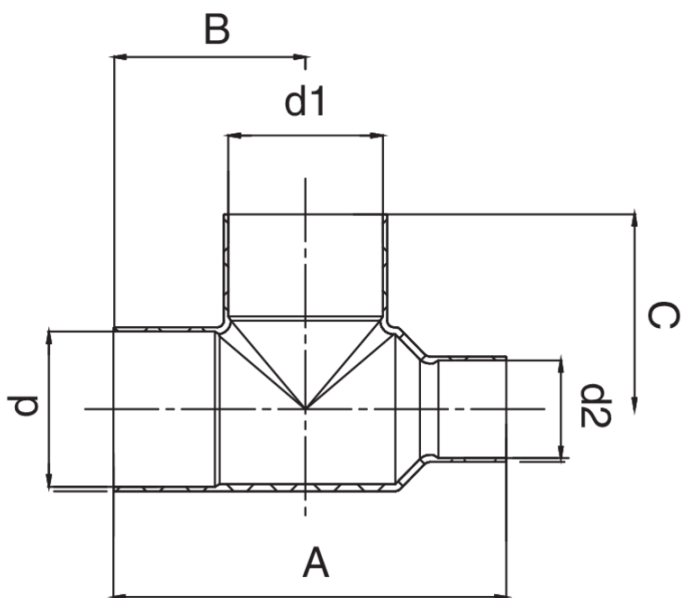

D X D1 X D2	BAG	MASTER BOX	CÓDIGO	A	B	C
28 x 22 x 22	5	50	RG5130028022022	67	33	33
28 x 28 x 22	10	100	RG5130028028022	70	35	35
35 x 22 x 22	5	80	RG5130035022022	72	36	35
35 x 28 x 28	5	20	RG5130035028028	76	38	38
35 x 35 x 28	5	20	RG5130035035028	87	43	44
42 x 28 x 35	5	50	RG5130042028035	85	43	42
42 x 35 x 35	5	20	RG5130042035035	94	47	48
54 x 35 x 42	1	10	RG5130054035042	102	51	52
54 x 42 x 42	1	10	RG5130054042042	110	55	56
54 x 54 x 42	1	15	RG5130054054042	126	61	62

Aplicaciones



GAS



COMPRESSED AIR



SOLAR



INDUSTRIAL



REFRIGERATION



DRINKING WATER



HVAC