

T reducido central H/H/H.

Especificaciones técnicas

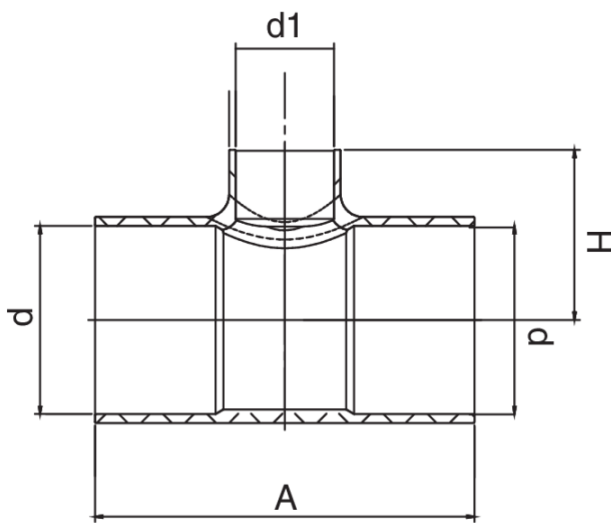

D X D1 X D	BAG	MASTER BOX	CÓDIGO	A	H
28 x 18 x 28	10	100	RG5130028018028	68	34
35 x 22 x 35	5	80	RG5130035022035	75	37,5
35 x 28 x 35	5	70	RG5130035028035	78	38
42 x 22 x 42	5	60	RG5130042022042	85	40
42 x 35 x 42	2	16	RG5130042035042	93	46

Aplicaciones



GAS



COMPRESSED AIR



SOLAR



INDUSTRIAL



REFRIGERATION



DRINKING WATER



HVAC