



FRABO

frabo
press
C-STEEL V
ZC0271

PATENTED

Manguito de paso H/H.

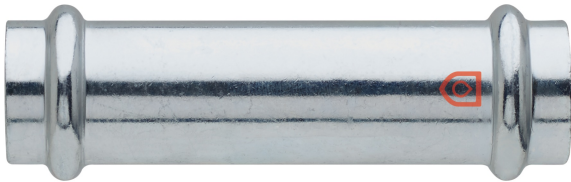

Especificaciones técnicas

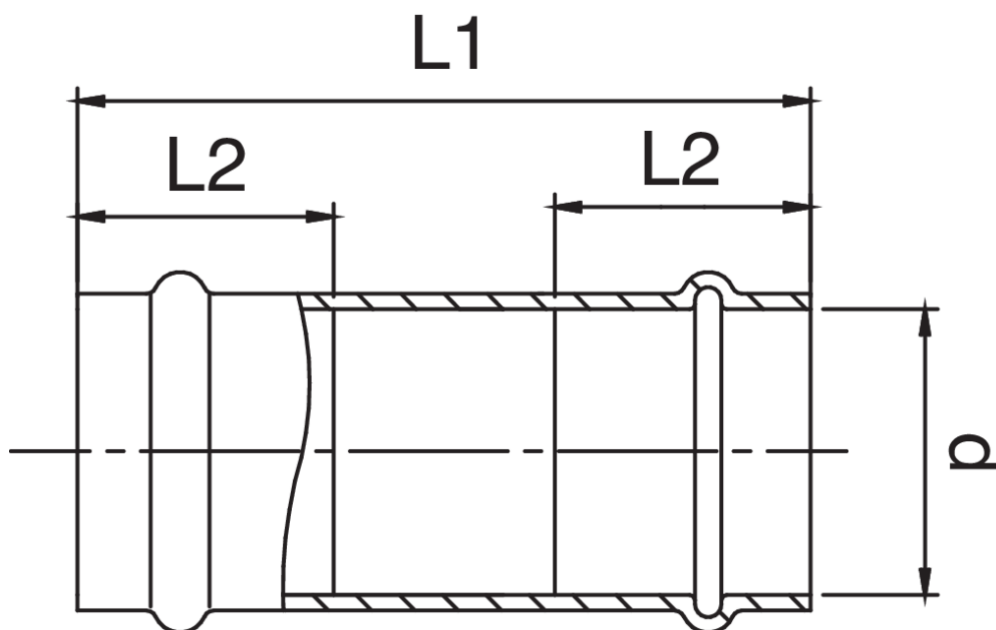

D	BAG	MASTER BOX	CÓDIGO	L1	L2
12	10	200	ZC0271012012000	57	18
15	10	150	ZC0271015015000	85	22
18	10	100	ZC0271018018000	96	23
22	5	30	ZC0271022022000	97	24
28	5	30	ZC0271028028000	107	25
35	1	20	ZC0271035035000	116	26
42	1	20	ZC0271042042000	142	36
54	1	10	ZC0271054054000	163	40

The big-size, item AC0271, is available.

Aplicaciones



HEATING



HVAC



COMPRESSED
AIR