

Curva 30° M/M.

Especificaciones técnicas

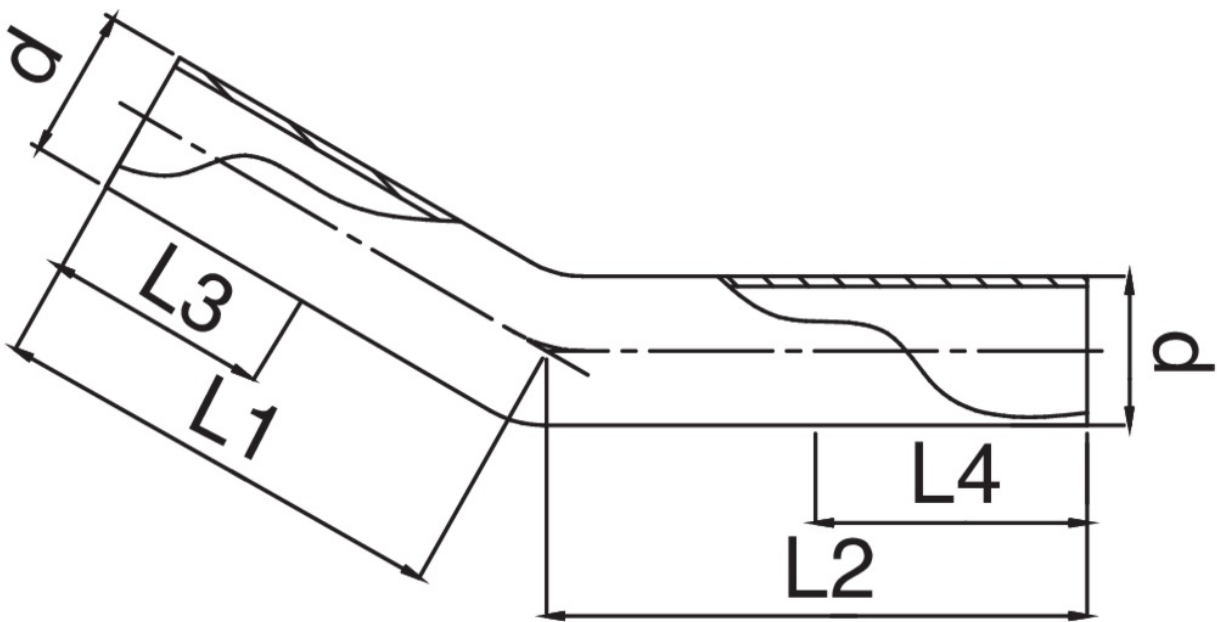

D	BAG	MASTER BOX	CÓDIGO	L1	L2	L3 MIN	L4 MIN
15	5	100	ZX0030015015000	60	122	25	25
18	10	100	ZX0030018018000	55	128	25	25
22	5	100	ZX0030022022000	50	124	30	30
28	5	20	ZX0030028028000	54	130	30	30
35	5	15	ZX0030035035000	80	218	30	30
42	2	10	ZX0030042042000	98	274	45	45
54	2	10	ZX0030054054000	137	324	65	65

Aplicaciones



DRINKING
WATER



HEATING



HVAC



COMPRESSED
AIR



FIREFIGHTING



MARINE



STEAM



SOLAR



INDUSTRIAL

