

RG5041

F/F 45° elbow.

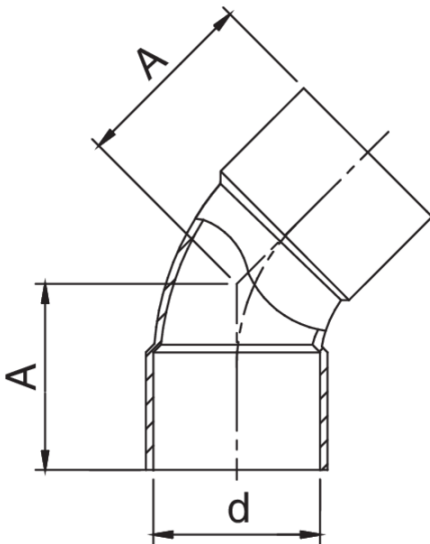

Technical specifications



D	BAG	MASTER BOX	CODE	A
22	10	350	RG5041022022000	27
28	10	200	RG5041028028000	33,5
35	5	100	RG5041035035000	40
42	5	60	RG5041042042000	46
54	1	10	RG5041054054000	55,5
133	1	2	RG5041133133000	110

Applications



GAS



COMPRESSED AIR



SOLAR



INDUSTRIAL



REFRIGERATION



DRINKING WATER



HVAC