

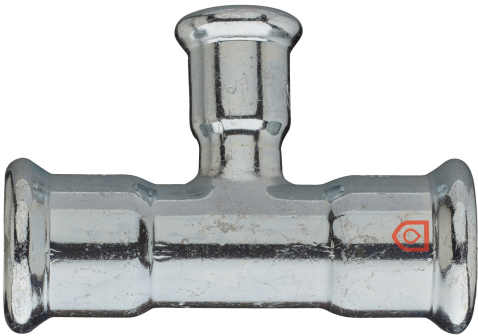

FRABO

frabo
press
C-STEEL M
CM0131

PATENTED



F/F/F reducing tee.



Technical specifications

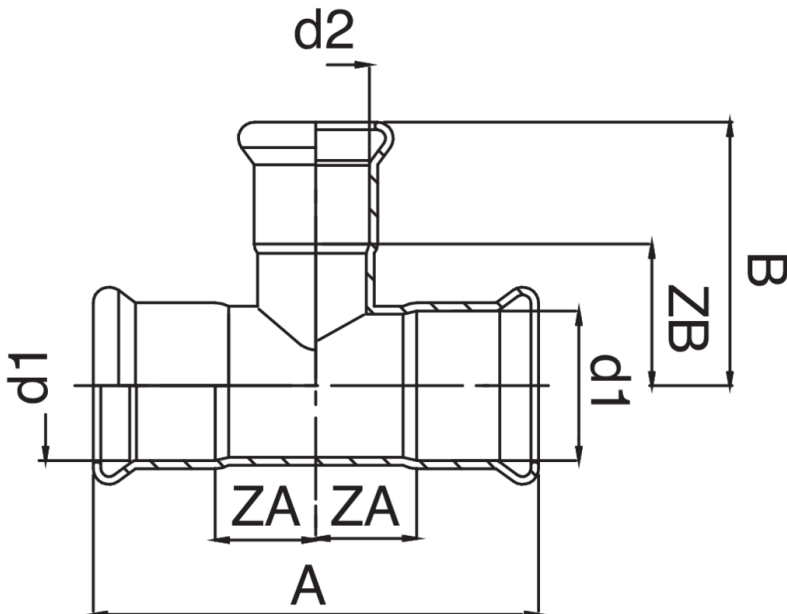

D1 X D2 X D1	BAG	MASTER BOX	CODE	A	B	ZA	ZB
15 x 22 x 15	10	70	CM0131015022015	75	42	18,5	19
18 x 15 x 18	10	80	CM0131018015018	80	36	21	17
18 x 22 x 18	5	50	CM0131018022018	80	43	21	20
22 x 15 x 22	5	50	CM0131022015022	82	38	20	19
22 x 18 x 22	5	50	CM0131022018022	82	38	20	19
22 x 28 x 22	5	40	CM0131022028022	82	46	20	23
28 x 15 x 28	5	30	CM0131028015028	92	42	24	23
28 x 18 x 28	5	30	CM0131028018028	92	42	24	23
28 x 22 x 28	5	30	CM0131028022028	92	45	24	23
35 x 15 x 35	5	25	CM0131035015035	102	45	26	26
35 x 18 x 35	5	25	CM0131035018035	102	45	26	26
35 x 22 x 35	5	20	CM0131035022035	102	46	26	24
35 x 28 x 35	5	20	CM0131035028035	115	53	32,5	31
42 x 22 x 42	3	15	CM0131042022042	130	56	36	35
42 x 28 x 42	1	10	CM0131042028042	130	57	36	35
42 x 35 x 42	1	10	CM0131042035042	130	61	36	36
54 x 22 x 54	1	10	CM0131054022054	160	63	46	42
54 x 28 x 54	1	10	CM0131054028054	160	64	46	42
54 x 35 x 54	1	10	CM0131054035054	160	68	46	43
54 x 42 x 54	1	10	CM0131054042054	160	76	46	47

Applications



HEATING



HVAC



COMPRESSED
AIR