

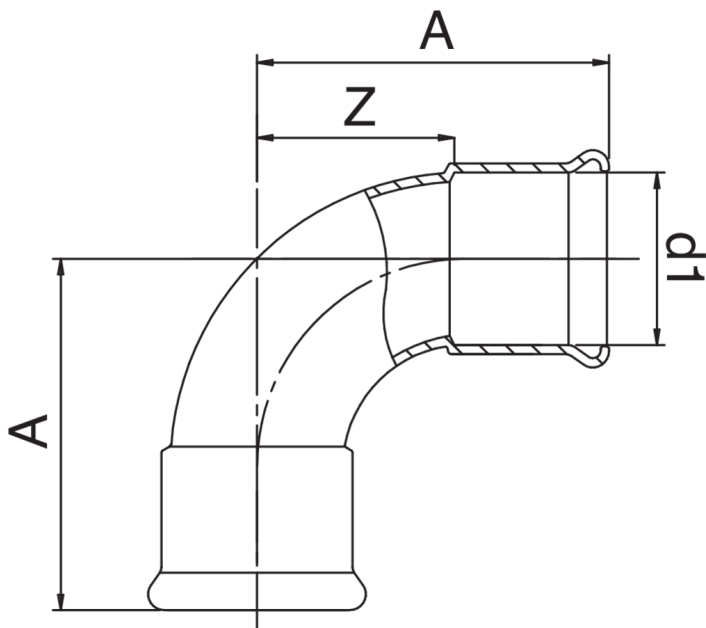

F/F 90° elbow.



## Technical specifications



| D1 | BAG | MASTER BOX | CODE            | A  | Z  |
|----|-----|------------|-----------------|----|----|
| 15 | 10  | 150        | CM0002015015000 | 36 | 16 |
| 18 | 10  | 100        | CM0002018018000 | 41 | 21 |
| 22 | 10  | 60         | CM0002022022000 | 46 | 23 |
| 28 | 5   | 40         | CM0002028028000 | 57 | 34 |
| 35 | 5   | 30         | CM0002035035000 | 62 | 36 |
| 42 | 1   | 10         | CM0002042042000 | 76 | 46 |
| 54 | 1   | 7          | CM0002054054000 | 94 | 59 |

## Applications



HEATING



HVAC



COMPRESSED  
AIR