

F/F/F reducing tee.

## Technical specifications

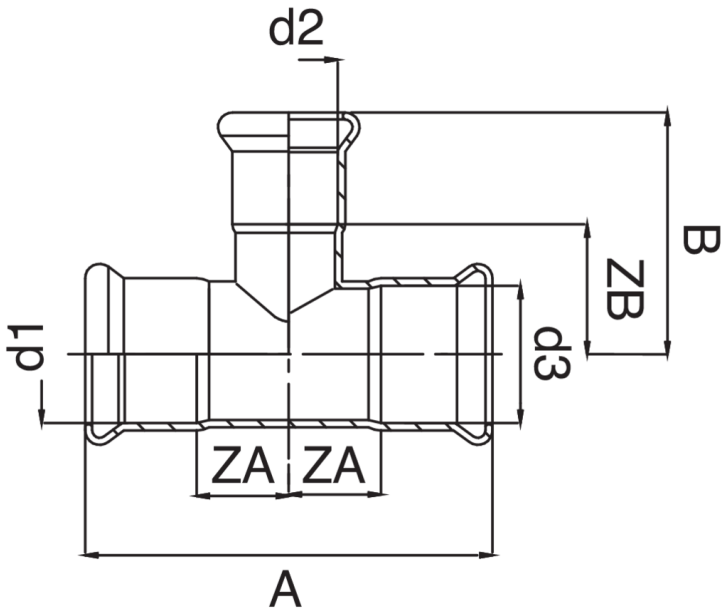

D1 X D2 X D3	BAG	MASTER BOX	CODE	A	B	ZA	ZB
18 x 15 x 18	5	30	GM0131018015018	96	56	28,5	36,5
22 x 15 x 22	5	40	GM0131022015022	98	48	26,5	28,5
22 x 18 x 22	5	25	GM0131022018022	98	51	26,5	31,5
28 x 15 x 28	5	15	GM0131028015028	112	61	33,5	41,5
28 x 18 x 28	5	15	GM0131028018028	94	47	24,5	24,5
28 x 22 x 28	5	15	GM0131028022028	112	54	33,5	34,5
35 x 15 x 35	1	15	GM0131035015035	136	65	42,5	45,5
35 x 18 x 35	1	15	GM0131035018035	132	60	40,5	40,5
35 x 22 x 35	1	10	GM0131035022035	132	59	40,5	36,5
35 x 28 x 35	1	15	GM0131035028035	132	62	40,5	39,5
42 x 22 x 42	1	8	GM0131042022042	156	63	48,5	40,5
42 x 28 x 42	1	6	GM0131042028042	156	75	48,5	52,5
42 x 35 x 42	1	5	GM0131042035042	156	75	48,5	49,5
54 x 22 x 54	1	5	GM0131054022054	184	67	57,5	44,5
54 x 28 x 54	1	5	GM0131054028054	184	72	57,5	49,5
54 x 35 x 54	1	5	GM0131054035054	184	90	57,5	64,5
54 x 42 x 54	1	5	GM0131054042054	184	109	57,5	79,5

## Applications



GAS



COMPRESSED  
AIR



INDUSTRIAL