

F/F coupling.

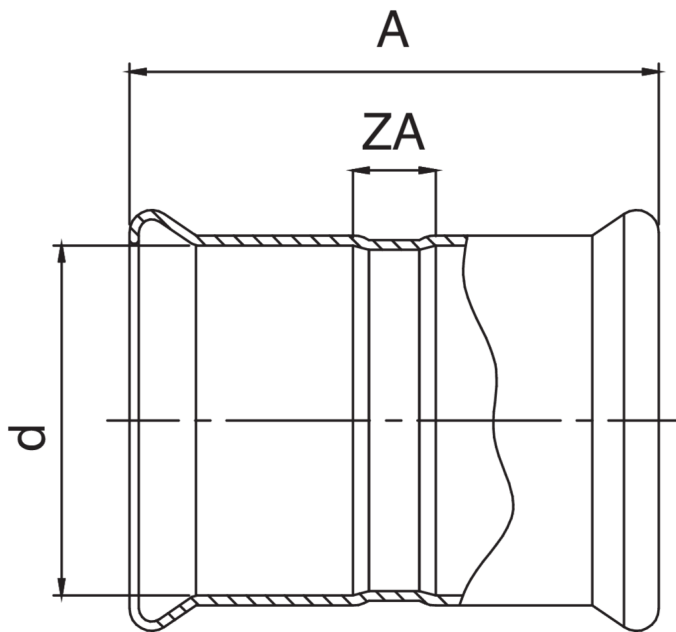

## Technical specifications



D	BAG	MASTER BOX	CODE	A	ZA
15	10	150	GM0270015015000	48	9
18	10	100	GM0270018018000	48	9
22	5	30	GM0270022022000	50	5
28	5	40	GM0270028028000	54	9
35	5	35	GM0270035035000	62	11
42	1	25	GM0270042042000	73	14
54	1	15	GM0270054054000	85	16

# Applications



GAS



COMPRESSED  
AIR



INDUSTRIAL