

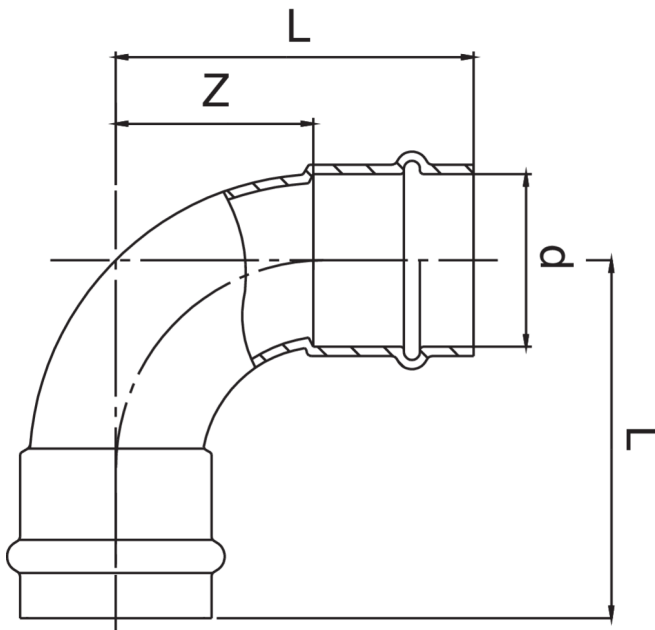

F/F 90° elbow.

## Technical specifications



D	BAG	MASTER BOX	CODE	L	Z
15	10	100	GX0002015015000	40	18
18	10	30	GX0002018018000	45	22
22	5	50	GX0002022022000	51	27
28	5	30	GX0002028028000	59	34
35	5	25	GX0002035035000	68	42
42	1	10	GX0002042042000	87	51
54	1	7	GX0002054054000	105	65

# Applications



GAS



COMPRESSED  
AIR



INDUSTRIAL