

Bronze F/F flat seat joint.

## Technical specifications

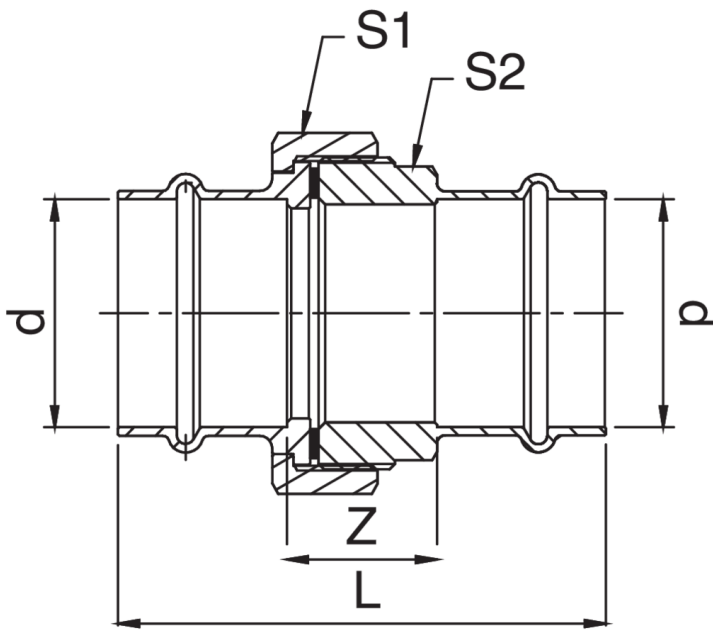

D	BAG	MASTER BOX	CODE	L	S1	S2	Z
15	10	100	PG8340015015000	73	24	25	29
18	10	100	PG8340018018000	78	30	31	32
22	5	40	PG8340022022000	86	37	34	38
28	5	30	PG8340028028000	86	46	42	36
35	5	20	PG8340035035000	93	52	50	41
42	1	10	PG8340042042000	118	64	60	46
54	1	8	PG8340054054000	115	85	75	35

# Applications



GAS



INDUSTRIAL



COMPRESSED  
AIR