



FRABO

frabo
press
316 M
MX0047



F/F 30° elbow.

NEW



Technical specifications

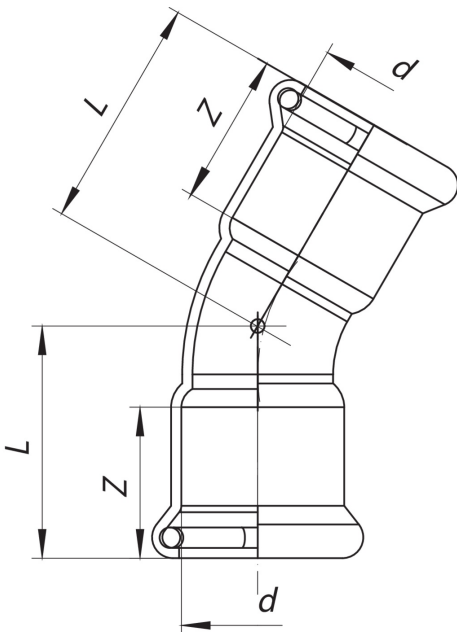

D	BAG	MASTER BOX	CODE	L	Z
15	10	250	MX0047015015000	32,5	19
18	10	250	MX0047018018000	29,5	19,5
22	5	120	MX0047022022000	34	21
28	5	60	MX0047028028000	36	22
35	5	40	MX0047035035000	61,3	27
42	2	30	MX0047042042000	75,8	30
54	2	16	MX0047054054000	90,5	35

Applications



DRINKING
WATER



HEATING



HVAC



COMPRESSED
AIR



FIREFIGHTING



MARINE



STEAM



SOLAR



INDUSTRIAL