

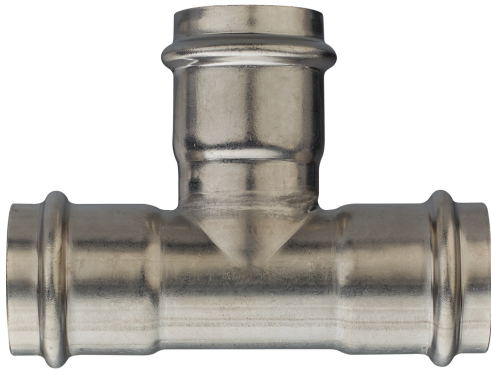

**FRABO**

**frabo**  
**press**  
316 V  
**ZX0130**

**PATENTED**



F/F/F tee.



## Technical specifications

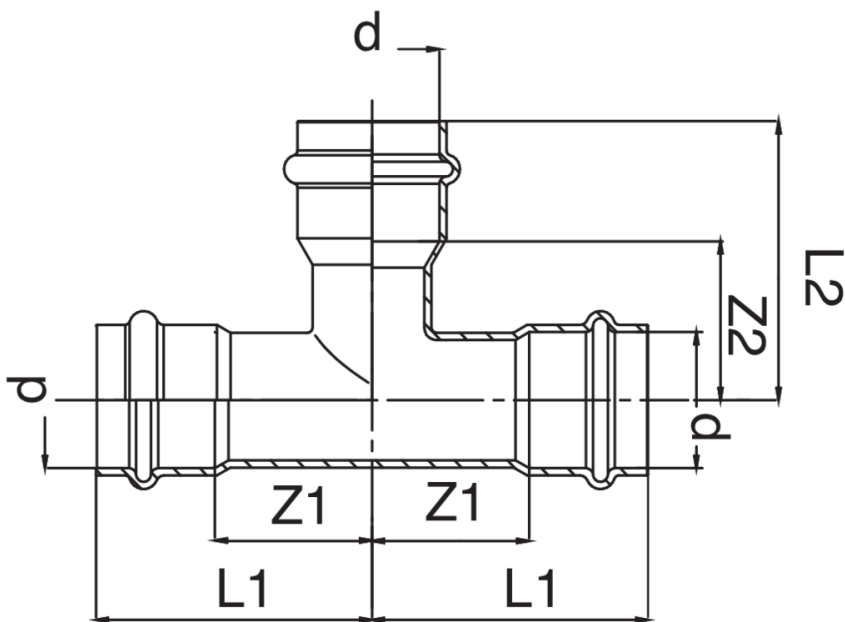

D	BAG	MASTER BOX	CODE	L1	L2	Z1	Z2
15	5	40	ZX0130015015015	42	44	20	22
18	5	50	ZX0130018018018	46	49	23	26
22	5	30	ZX0130022022022	49	53	25	29
28	5	20	ZX0130028028028	56	57	31	34
35	1	15	ZX0130035035035	66	63	42	37
42	1	10	ZX0130042042042	78	76	44	40
54	1	5	ZX0130054054054	82	92	42	51

The big-size, item AX0130, is available.

## Applications



DRINKING  
WATER



HEATING



HVAC



COMPRESSED  
AIR



FIREFIGHTING



MARINE



STEAM



SOLAR



INDUSTRIAL