

Winkel 90° I/A.

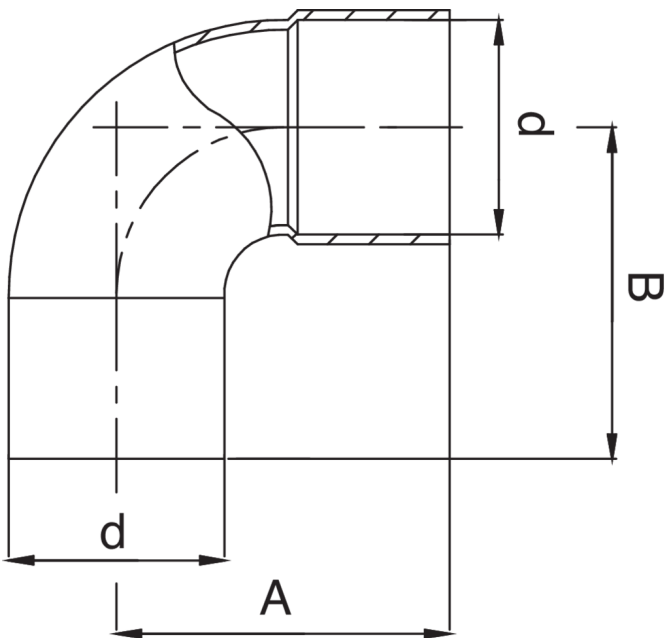

Technische Spezifikationen



D	BAG	MASTER BOX	CODE	A	B
6	10	1000	RR5092006006000	14	16
8	25	1000	RR5092008008000	16,5	18,5
10	10	500	RR5092010010000	17	19
12	10	400	RR5092012012000	19,5	21,5
14	10	400	RR5092014014000	23	25
15	10	300	RR5092015015000	25	27
16	10	300	RR5092016016000	24,5	26,5
18	10	250	RR5092018018000	28,5	30,5
20	10	350	RR5092020020000	27	29,5
22	10	130	RR5092022022000	33	35
28	10	60	RR5092028028000	42	44
32	5	100	RR5092032032000	40,5	44
35	5	100	RR5092035035000	52	54
36	5	100	RR5092036036000	42,5	46,5
40	5	50	RR5092040040000	49	52,5
42	5	50	RR5092042042000	59	61
52	1	10	RR5092052052000	59,5	63,5
54	1	10	RR5092054054000	65	70
63	1	6	RR5092063063000	71	74
64	1	8	RR5092064064000	72	75
66,7	1	8	RR5092067067000	72	75
76,1	1	10	RR5092076076000	81	86
80	1	10	RR5092080080000	86	90
88,9	1	10	RR5092089089000	92,5	96
108	1	5	RR5092108108000	113,5	115,5

Anwendungen



DRINKING
WATER



HEATING



HVAC



GAS



COMPRESSED
AIR



SOLAR



INDUSTRIAL